

The copyright of this drawing is owned by FRICON.

The drawing shall not be reproduced or its contents disclosed to a third without written permission from FRICON.

\\172.24.15.201\Desenho\01-SUPERMERCADOS\030 - SMR SLB 170\CO-COMERCIAL\DRAWING 2D\AUTOCAD

General linear tolerance

Dimensions	0.5 ... 3	>3 ... 120	>120 ... 1000	>1000 ... 4000
Deviation (mm)	±0.2	±0.5	±1	±2

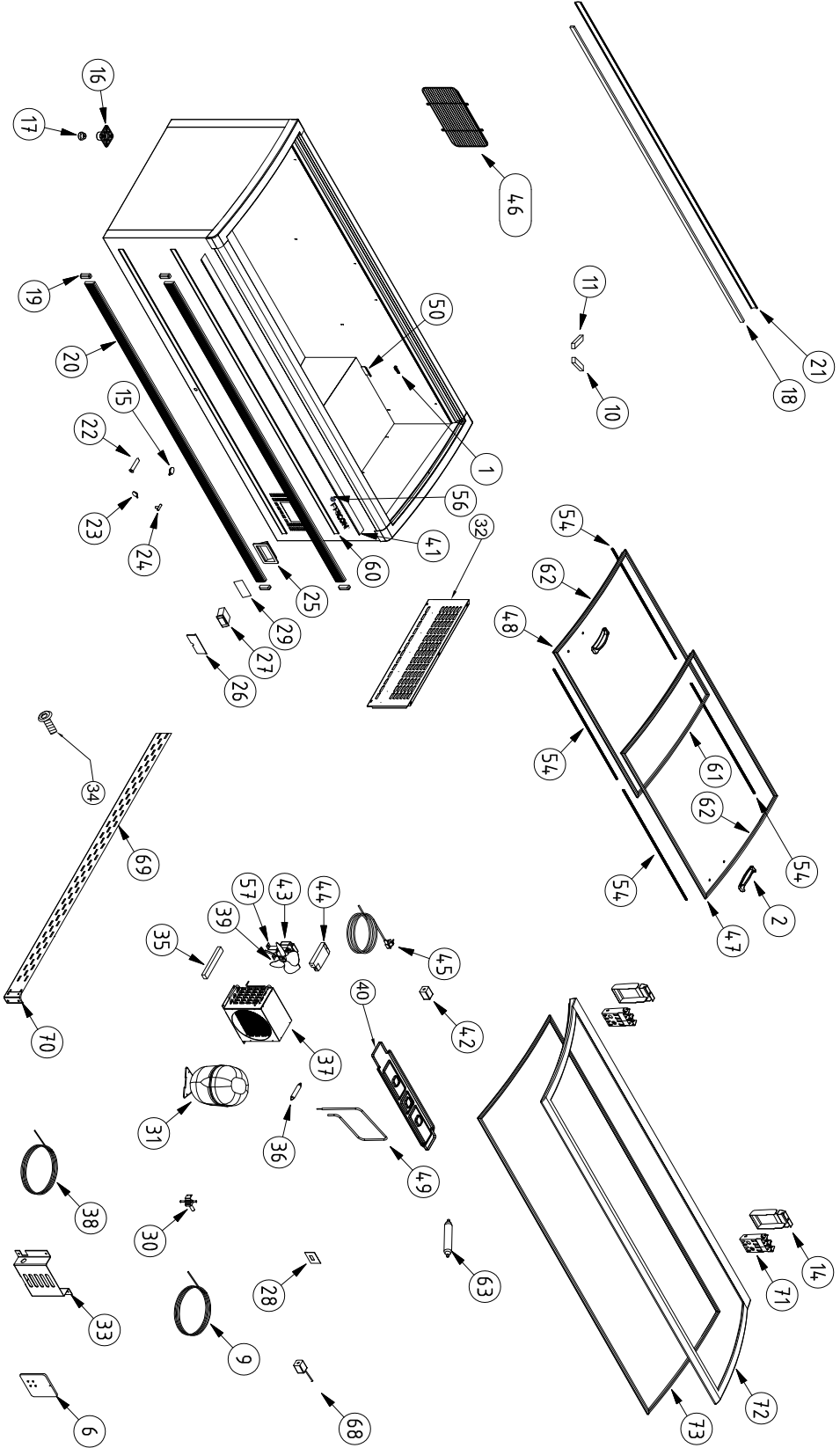

Verified  
Verified date  
Designer  
Drawer date  
Scale

SE  
DIN A4  
A  
Change  
Rev.  
Date  
Designer  
Project  
SMR 1700 SLB AD  
Description  
DESENHO EXPLORÇÃO SMR 1700 SLB AD

24/05/2022  
Leonel  
21/12/2021  
Leonel  
Part Code  
CNC Program  
Material  
Thickness

05/07/2021  
André Silva  
A  
Inclusão novos acessórios  
Date  
Designer  
Drawing code  
CO 01 030 004



1 2 3 4 5 6

1 2 3 4 5 6

D C B A

A B C D

The copyright of this drawing is owned by FRICON.

The drawing shall not be reproduced or its contents disclosed to a third without written permission from FRICON.

\\172.24.15.201\Desenho\01-SUPERMERCADOS\030 - SMR SLB 170\CO-COMERCIAL\DRAWING 2D\AUTOCAD

**General linear tolerance**

Dimensions	0.5 ... 3	>3 ... 120	>120 ... 1000	>1000 ... 4000
Deviation (mm)	±0.2	±0.5	±1	±2

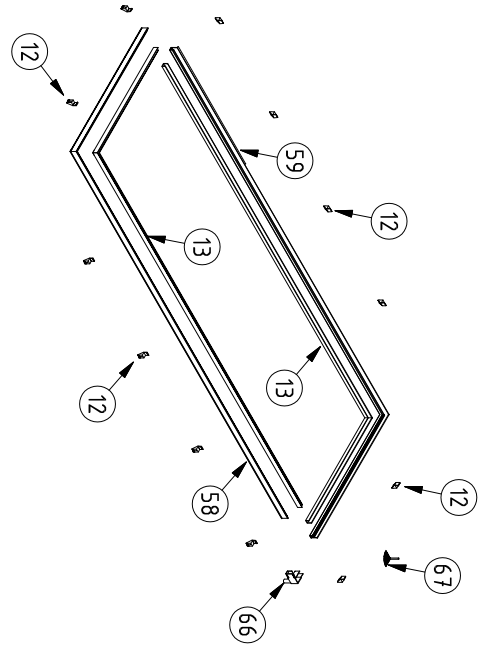
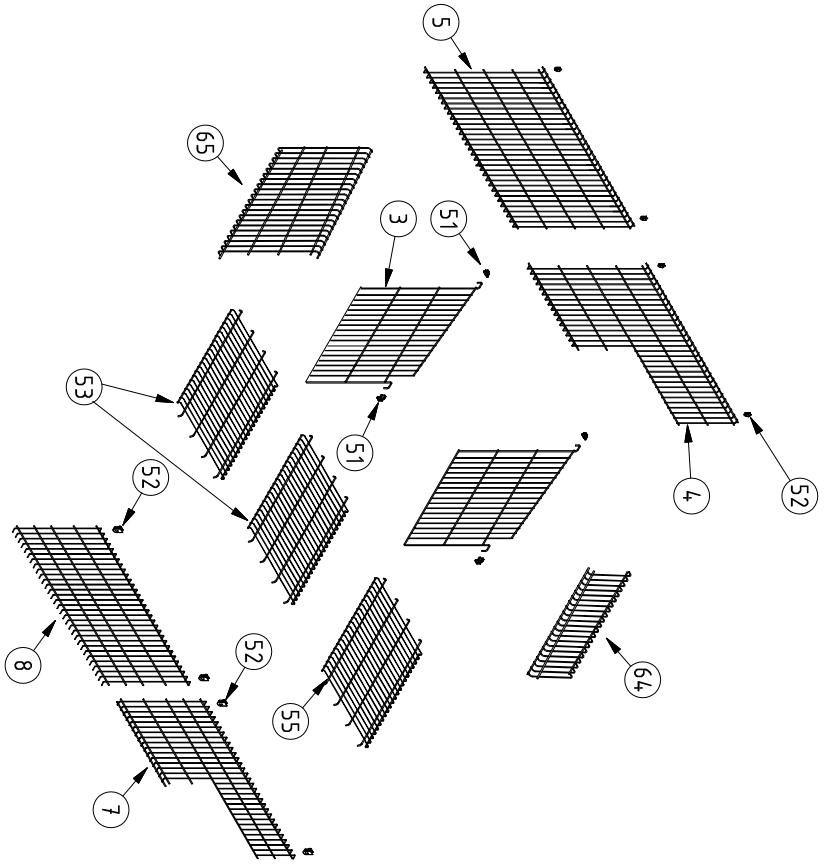

Verified							Project <b>SMR 1700 SLB AD</b>
Verified date							Description DESENHO EXPLOSIÃO SMR 1700 SLB AD
Designer	André Silva						Drawing code Sector: <b>CO 01 030 004</b> Product: <b>CO 01 030 004</b> Part: <b>CO 01 030 004</b> Spec: <b>CO 01 030 004</b>
Drawer date	05/07/2021	Rev.	Change	Date	Designer		Part Code
Scale	SE						CNC Program
	DIN A4						Material
							Thickness

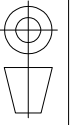

Grid lines: A, B, C, D (horizontal); 1, 2, 3, 4, 5, 6 (vertical)

Equipment Model: SMR 1700 SLB AD 230V/50HZ				Updated:	
Drawing Number: CO 01 030 004				23/05/2022	
N°	Code	Description	Quantity	Unit	
1a	511.1259	WHITE PROBE'S SUPPORT	1	UN	
1b	511.0343	BLACK PROBE'S SUPPORT	1	UN	
2a	511.0286	200MM SLIDING LID HANDLE RAL7042	1	UN	
2a+	C511.0286	200MM SLIDING LID HANDLE RAL7042 W/SCREWS	2	UN	
2b	511.0453	200MM SLIDING LID HANDLE BLACK	2	UN	
2b+	C511.0453	200MM SLIDING LID HANDLE BLACK W/SCREWS	2	UN	
3a	513.0071	WHITE BIG DIVIDER SMR WITH SUPPORTS	2	UN	
3b	513.0307	BLACK BIG DIVIDER SMR WITH SUPPORTS	2	UN	
4a	513.0014	WHITE BACK STEP SIDE SHELF SUPPORT	1	UN	
4b	513.0310	BLACK STEP SIDE SHELF SUPPORT	1	UN	
5a	513.0023	WHITE BACK SHELF SUPPORT	1	UN	
5b	513.0434	BLACK BACK SHELF SUPPORT	1	UN	
6	515.0991	WHITE PLASTIC SPACER	1	UN	
7a	513.0013	WHITE FRONT STEP SIDE SHELF SUPPORT	1	UN	
7b	513.0311	BLACK FRONT STEP SIDE SHELF SUPPORT	1	UN	
8a	513.0017	WHITE FRONT SHELF SUPPORT	1	UN	
8b	513.0433	BLACK FRONT SHELF SUPPORT	1	UN	
9a	03.0499	NTC015HP00 1,5M PROBE	2	UN	
9b	03.0347	DANFOSS EKS-111PTC 1000 1,5MT PROBE	2	UN	
10a	511.0936	SMR R7042 RIGHT LID STOP	1	UN	
10b	511.0456	SMR BLACK RIGHT LID STOP	1	UN	
11a	511.0937	SMR R7042 LEFT LID STOP	1	UN	
11b	511.0457	SMR BLACK LEFT LID STOP	1	UN	
12a	511.0971	WHITE DRAIN CHANNEL/EVAPORATOR SUPPORT	18	UN	
12b	511.0451	BLACK DRAIN CHANNEL/EVAPORATOR SUPPORT	18	UN	
13	515.0822	ALUMINUM GUTTER 2230MM	2	UN	
14a	01.0710	WHITE DOUBLE HINGE COVER	2	UN	
14b	01.1686	BLACK DOUBLE HINGE COVER	2	UN	
15a	511.0105	WHITE INTERIOR DRAIN PLUG	1	UN	
15b	511.0204	BLACK INTERIOR DRAIN PLUG	1	UN	
16a	511.0021	75MM FEET	4	UN	
16a+	C511.0021	75MM FEET WITH LEVELER	4	UN	
16b	511.0220	85MM FEET	4	UN	
16b+	C511.0220	85MM FEET WITH LEVELER	4	UN	
16c	511.0626	150MM FEET	4	UN	
16c+	C511.0626	150MM FEET WITH LEVELER	4	UN	
17	511.0017	M12 X 50MM LEVELER	4	UN	
18	03.1249	LED LAMP 24V 1500+700 5000K	1	UN	
19	C511.0507	BLACK RIBBED BUMPER TOP	4	UN	
20	01.1053	BLACK RIBBED BUMPER 1670MM	2	UN	
21	511.0899	LAMP DIFUSOR 1554MM	1	UN	
22a	511.0347	WHITE DRAIN PIPE	1	UN	
22b	511.0348	BLACK DRAIN PIPE	1	UN	
22c	511.0349	RAL7035 DRAIN PIPE	1	UN	
23a	511.0825	WHITE EXTERIOR DRAIN PLUG	1	UN	
23b	511.0166	BLACK EXTERIOR DRAIN PLUG	1	UN	

Equipment Model: SMR 1700 SLB AD 230V/50HZ				Updated:	
Drawing Number: CO 01 030 004				23/05/2022	
N°	Code	Description	Quantity	Unit	
23c	511.0228	RAL7035 EXTERIOR DRAIN PLUG	1	UN	
24	511.0107	DRAIN PURGE	1	UN	
25a	512.0116	R7042 CONTROL PANEL WITHOUT SWITCH	1	UN	
25a+	C512.0117	CONTROL PANEL WITH STICKER WITHOUT SWITCH	1	UN	
25b	512.0301	BLACK CONTROL PANEL WITHOUT SWITCH	1	UN	
25b+	C512.0301	BLACK CONTROL PANEL WITH STICKER WITHOUT SWITCH	1	UN	
26	01.1040	ACRILIC LID FOR CONTROL PANEL 135X57MM	1	UN	
27a	03.0969	CAREL IR33 + IREV CONTROLLER	1	UN	
27b	03.0533	DIXELL XR75CX CONTROLLER	1	UN	
27c	03.0231	DANFOSS AKCC 211 CONTROLLER	1	UN	
28	515.0015	JOINERS SUPPORT	4	UN	
29a	07.0874	SWITCHLESS CONTROL PANEL'S LABEL 134X51MM	1	UN	
29b	07.0903	BLACK SWITCHLESS CONTROL PANEL'S LABEL 134X51MM	1	UN	
30	02.0323	SANHUA DEFROST VALVE 1/4	1	UN	
31	02.0652	EMBRACO EHX2155U COMPRESSOR 220-240V/50HZ	1	UN	
32a	515.0613	WHITE EXTERIOR SIDE PLATE GRID	1	UN	
32b	515.0416	BLACK EXTERIOR SIDE PLATE GRID	1	UN	
33	515.0989	WHITE OMEGA PLATE	1	UN	
33+	C515.0989	OMEGA PLATE WITH SCREW AND CABLE GLAND	1	UN	
34	05.0316	KICK-PLATE SCREW	4	UN	
35	03.0963	LED BAR TRANSFORMER 60W 800MM ASQC2	1	UN	
36	02.0564	7,5G FILTER IN-6/OUT-3 (R290/R600)	1	UN	
37	02.0577	WIRE ON TUBE CONDENSER	1	UN	
38	03.1318	NTC IP67 6MT PROBE	1	UN	
38+	C03.1318	PROBE WITH PLASTIC AND SCREW	1	UN	
39	02.0079	ASPIRANT HELIX Ø200MM 28°	1	UN	
40	512.0295	WATER TRAY	1	UN	
41	511.0703	PRICE HOLDER 1545MM	1	UN	
42	02.0606	SANHUA DEFROST SOLENOIDE VALVE 12W	1	UN	
43	02.0312	FAN MOTOR 10W 230V 50-60HZ	1	UN	
44	03.0834	CONNECTION BOX	1	UN	
45a	03.0177	POWER CABLE 3G1,5MM TYPE-E/F WHITE	1	UN	
45b	03.0534	POWER CABLE 3G1,5MM TYPE-E/F BLACK	1	UN	
46a	513.0046	RECTANGULAR WHITE EXTERIOR WIRED GRID 430X220MM	1	UN	
46b	513.0208	RECTANGULAR BLACK EXTERIOR WIRED GRID 430X220MM	1	UN	
47a	09.2756	SUPERIOR SLIDING GLASS LID SMR 801X774MM	1	UN	
47a+	C09.2756	SMR'S SUPERIOR SLIDING GLASS LID WITH HANDLE	1	UN	
47b	09.2971	BLACK SUPERIOR SLIDING GLASS LID SMR 801X774MM	1	UN	
47b+	C09.2971	SMR'S BLACK SUPERIOR SLIDING GLASS LID WITH HANDLE	1	UN	
48a	09.2755	INFERIOR SLIDING GLASS LID SMR 801X753MM	1	UN	
48a+	C09.2755	SMR'S INFERIOR SLIDING GLASS LID WITH HANDLE	1	UN	
48b	09.2970	BLACK INFERIOR SLIDING GLASS LID SMR 801X753MM	1	UN	
48b+	C09.2970	SMR'S BLACK INFERIOR SLIDING GLASS LID WITH HANDLE	1	UN	
49	03.1308	RESISTANCE 220V/100W	1	UN	
50	515.0008	DEFROST PROBE'S SUPPORT PLATE	1	UN	

Equipment Model: SMR 1700 SLB AD 230V/50HZ				Updated:	
Drawing Number: CO 01 030 004				23/05/2022	
N°	Code	Description	Quantity	Unit	
51a	511.0854	WHITE PLASTIC DIVIDER SUPPORT	4	UN	
51b	511.0450	BLACK PLASTIC DIVIDER SUPPORT	4	UN	
52a	511.0851	WHITE PLASTIC WALL SHELF SUPPORT	8	UN	
52b	511.0444	BLACK PLASTIC WALL SHELF SUPPORT	8	UN	
53a	513.0004	WHITE 500MM WIRE SHELF	2	UN	
53b	513.0312	BLACK 500MM WIRE SHELF	2	UN	
54	C01.0829	LID'S SLIDING PROFILE 795MM	4	UN	
55a	513.0003	WHITE 450MM WIRE SHELF	1	UN	
55b	513.0313	BLACK 450MM WIRE SHELF	1	UN	
56	07.0817	"FRICON" STICKER	1	UN	
57	09.0988	FAN MOTOR SUPPORT 72MM	1	UN	
58a	01.1599	WHITE DRAIN CHANNEL INFERIOR 1520X718MM	1	UN	
58b	01.1659	BLACK DRAIN CHANNEL INFERIOR 1520X718MM	1	UN	
59a	01.1674	WHITE DRAIN CHANNEL SUPERIOR 1555X688MM	1	UN	
59b	01.1684	BLACK DRAIN CHANNEL SUPERIOR 1555X688MM	1	UN	
60	01.1458	BUMPER SUPPORT 1640MM	2	UN	
61	01.1163	LID SEAL PROFILE 9MM	1	UN	
62	01.1227	LID SEAL PROFILE 10 X 760MM	3	UN	
63	02.0643	DEFROSTING FILTER	1	UN	
64a	513.0325	WHITE STEP SIDE SHELF SUPPORT	1	UN	
64b	513.0474	BLACK STEP SIDE SHELF SUPPORT	1	UN	
65a	513.0324	WHITE SIDE SHELF SUPPORT	1	UN	
65b	513.0475	BLACK SIDE SHELF SUPPORT	1	UN	
66a	511.0020	WHITE DEFROST CORNER WITH HOLE	1	UN	
66b	511.0864	BLACK DEFROST CORNER WITH HOLE	1	UN	
67a	511.0283	WHITE DRAIN CHANNEL'S FILTER	1	UN	
67b	511.0452	BLACK DRAIN CHANNEL'S FILTER	1	UN	
68a	03.0572	COMUNICATION MODULE IROPZ48500	1	UN	
68b	03.0601	COMUNICATION MODULE TTL-RS485 DIXEL	1	UN	
68c	03.0348	COMUNICATION CARD DANFOSS EKA-179A (LON)	1	UN	
	03.0808	COMUNICATION CARD DANFOSS EKC178A (MODBUS)	1	UN	
69a	519.0023	FRONTAL KICK PLATE "FEET 75MM"	1	UN	
69a+	C519.0023	FRONTAL KICK -PLATE WITH UNION AND SCREWS "FEET 75MM"	1	UN	
69b	519.0033	FRONTAL KICK PLATE "FEET 85MM"	1	UN	
69b+	C519.0033	FRONTAL KICK -PLATE WITH UNION AND SCREWS "FEET 85MM"	1	UN	
69c	519.0050	FRONTAL KICK PLATE "FEET 125MM"	1	UN	
69c+	C519.0050	FRONTAL KICK -PLATE WITH UNION AND SCREWS "FEET 125MM"	1	UN	
70a	519.0066	KICK PLATE JOINER "FEET 75MM"	1	UN	
70a+	C519.0066	KICK -PLATE UNION WITH SCREWS "FEET 75MM"	1	UN	
70b	519.0036	KICK PLATE JOINER "FEET 85MM"	1	UN	
70b+	C519.0036	KICK -PLATE UNION WITH SCREWS "FEET 85MM"	1	UN	
70c	519.0065	KICK PLATE JOINER "FEET 125MM"	1	UN	
70c+	C519.0065	KICK -PLATE UNION WITH SCREWS "FEET 125MM"	1	UN	
71	515.0018	DOUBLE HINGE HCL 4700 4,7MM	2	UN	
72	09.1428	SMR 1700'S LIFTING GLASS LID	1	UN	
73	09.1194	SMR 1700'S LIFTING LID RUBBER	1	UN	